

RIGID AND FLEXIBLE STRIP HEATERS

Strip heaters are heating elements of little thickness, rigid or flexible according to the models, particularly adapted to the installations, which have a little amount of space.

The majority of the strip heaters transfer their heat with the part to heat by conduction. They are used in numerous applications such as the heating of mould, of injection moulding machines, of sealing tools, in installations of thermal compression moulding or for the heating of tanks.

According to the applications and their proportioning, some heaters are used to give out by radiation to heat or cook some materials in installations such as tunnels or ovens for example.

Because of their design, the flexible heaters are not very much high loaded and work to a low temperature. They are particularly advised to maintain the temperature, notably of fragile products. Their thin thickness endow them a low thermal inertia.

Conversely, the rigid strip heaters, thicker, more powerful and working at higher temperatures, must perfectly have slantings on parts which have sides perfectly flat.

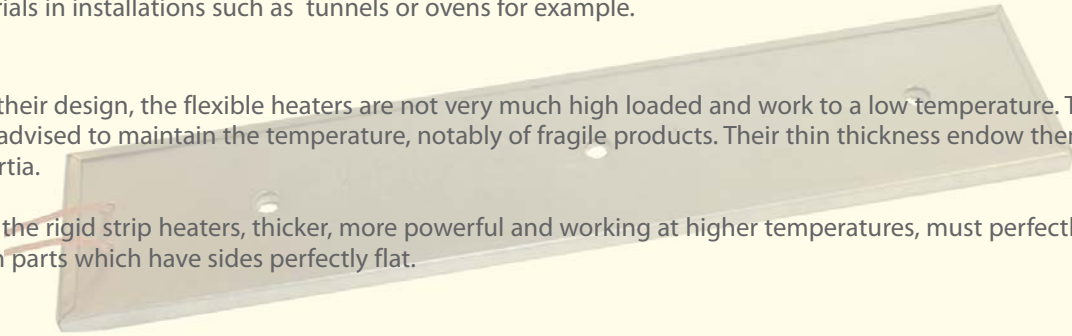

All these heaters can be made to measure with cuts and piercings in order to adapt perfectly to the parts to heat.

This technologie comes in a avariety of forms :

- o **Unshield mica strip heaters**..... heaters without mechanical protection
- o **Mica strip heaters**..... Applications for rigid heaters with slantings
- o **Sealed mica strip heaters** Humid environment
- o **Radiant type ceramic strip heaters** Heating by radiation
- o **Rigid ceramic strip heater**..... High temperatures

- o **Silicone heaters** Flexible silicone rubber heaters

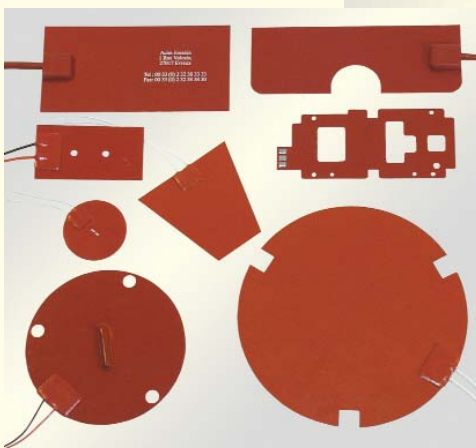
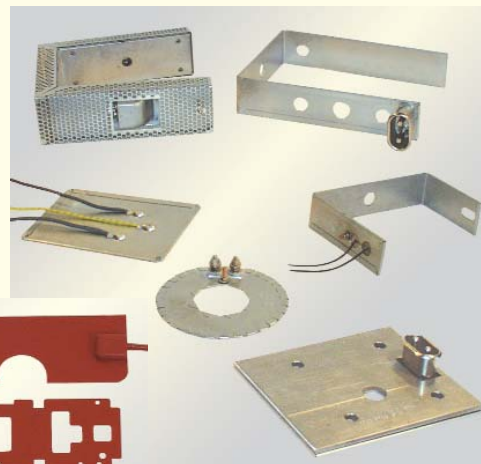

MICA STRIP HEATERS	
Mica strip heaters	p 2
Encapsulated sealed mica strip heaters	p 3
Unshield mica strip heaters	p 3
Connection types	p 4
Options	p 6
Examples of special mica strip heaters	p 7
Recommendations of assembly	p 7
Define a mica strip heater	p 8
CERAMIC STRIP HEATERS	
Radiant ceramic strip heaters	p 9
Rigid ceramic strip heaters	p 10
Recommendations of assembly	p 9
Define a ceramic strip heater	p 10
FLEXIBLE STRIP HEATERS	
Standard silicones	p 12
Special silicones	p 13
Special flexible heaters	p 14

MICA STRIP HEATERS

- Heating elements customer made coming in complement of the range of standard products in stock, defined below .
- Max. watt density over the surface of the heater : 4 W/cm².
- Max. working temperature on the strip heater : 340°C.
These parameters depend on the using recommandation and the connection type.
- Width : from 10 to 600 mm
- Length : from 60 to 2000 mm, according to a feasibility study.
(mini length according to the type of connection choosen.)
- Thickness : 3.2 mm for a length inf. to 1200mm.
Beyond, thickness between 3.6 and 3.8 mm
(*without connection*).
- Aluminized sheath in standard. Stainless steel or inconel in option.
- Electrical insulation in mica.
- Voltage : 500Vac max., single phase or three-phase
(three-phase : mini width :90mm)
- Number of connection : 1 or several, according to the intensity.
- Connection type :
 - without cap : standard leads (340°C) or high temperature leads (400°C max), terminal or plug.
 - with cap : Terminals, plug or braid.
 Earth bolt on demand.
See definition of the connection p.4
- Manufacturing according to the standard EN 60335-1
 - Wattage tolerance : +5%-10%
 - Leakage current < 0.75 mA/kW
- Define a strip heater, see p.8



- Special manufacturing : consult us.
 - Heating elements provided with accessories and options, p.6.
 - Heating element with a special shape (see below, for example) or cuts. Example of realization, see p.7.
 - UL approved for the USA and CSA approved for Canada. File number : E251509.
 - Example of special shape : Circular mica strip heaters :
Dimensional : from diameter 40 to 600 mm.
Connection : - leads, terminals, or
- connection box from diameter 120 mm.



MICA STRIP HEATERS IN STOCK

- Standard heating elements in stock available in 2 versions :
 - Basic model : had to be clamped in both sides. Especially used in press plates ...
 - Model with thermal insulation: used on installations where only the side without thermal insulation is in contact with the part to be heated. The other side, insulated by fibrous insulating coat under the screening, allows to limit the heating loss.
- Connection :
 - Nickel core leads, fiberglass silk silicone insulated, protected by two ceramic pearls, under stamp.
 - Connection situated on the top of the element, on the same side, centered on the width of the element. Gap :19mm.
 On request : earth wiring by the stud bolt.
- Thermal insulation model : provided with three holes for mounting system, Ø 10 mm.

- Max. watt density over the surface of the heater : 2.7 W/cm².
- Voltage : 230V single phase
- Dimensional of a mica strip heater :

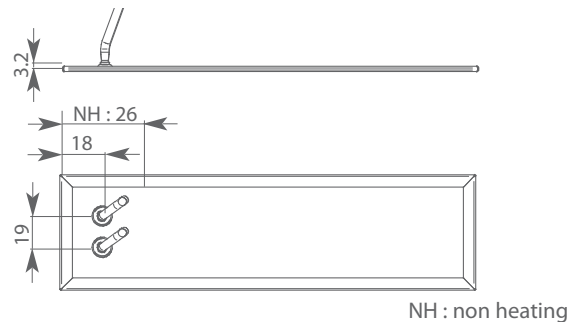

– Thermal insultaed model :

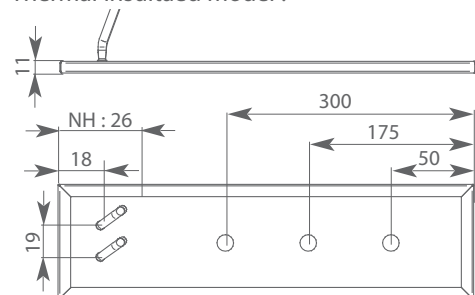

Designation	Length L (mm)	Width (mm)	Th.* (mm)	Watt. P (W)	Leads L (mm)	Stock
Basic model	230	80	3,2	500	2000	PMB 230 500
	380	80	3,2	750	2000	PMB 380 750
Insulated model	380	80	11	750	2000	P4.444

* Thickness without connection

Our products specifications are subject to change without notice. We reserve the right to modify them according to the technical evolution

- Tailor made strip heaters.
- Max. watt density over the surface of the heater : 4 W/cm^2 .
- Max. working temperature on the strip heater : 340°C .
These parameters depend on the using recommandation and the connection type.
- Heaters available in 2 versions :
 - Encapsulated sealed mica strip heaters,
 - Sealed mica strip heaters, up to 90 mm large.
- Width : Encapsulated sealed strip heaters : 20 to 90 mm.
Sealed heaters : 91 to 215 mm.
Width define with a multiple of 5 mm
- Length : Encapsulated mica strip heaters : 80 to 450 mm.
Sealed heaters : 450 to 1180 mm.
Length > 1200 mm, according to a faisabilty study
- Thickness : Encapsulated mica strip heaters : 2.8 to 3 mm
Sealed heaters : 3 to 3.2 mm
Informations for a heater's length < 1200 mm. Thickness without connection.
- Voltage: 500 Vac max., single phase.
- Electric insulation with mica.
- Manufacturing according to the standard EN 60335-1
 - Wattage tolerance : +5%-10%
 - Leakage current < 0.75 mA/kW



- Material : brass in standard model.
 - Encapsulated mica strip heaters: Encapsulated with fold over and brased extremities
 - Sealed heaters : Sheat in brased or welded brass according to the model.
Technology sealed to plastic.
- Connection :
 - Without cap : lead in the width. Specify the necessity of connection to the earth or not.
 - Under a small cap such as CMBPE : lead+ earth leads, under galvanized steel lead. Orientation of the connection box : axial, 30° . See definition of connection, p.5.
- Special manufacturing :
 - Accessories and options
 - Possibility of manufacturing in stainless steel.
 - Define a special strip heaters, see p.8.

NON METAL SHEATH MICA STRIP HEATERS

- Tailor made strip heaters.
- Max. watt density over the surface of the heater : 4 W/cm^2 .
- Max. working temperature on the strip heater : 340°C .
These parameters depend on the using recommandation and the connection type.
- Width : 20 to 600 mm, according to the feasablility study.
- Length : 50 to 1100 mm (Min Lg according to the connection)
- Thickness : 1.2mm, without connection.
- Electrical insulation by mica.
The heating elements have not mechanical protection. We have to protect them notably against mechanical shocks.
- Connection :
 - Leads : - nickel core, insulated by flexible silicone rubber. (Max working temperature : 180°C)
- nickel, insulated with fiberglass silk silicone (Max. working temperature : 340°C)
 - Nickel steel, ring faston terminal cable lug.
- Disposition of the connection :
 - In the width in standard or on the top, according to a feasibility study.
 - Disposition : on the same side, on both sides.
See definition of the connections, p.4.
- Voltage :230V for standard. Voltage : max.500 Vac. ...

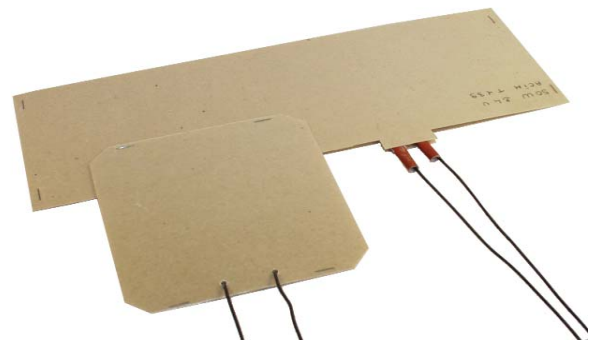

... Single phase or three-phases (from width 90mm)
6 leads connection : three-phases, commutable 230V/400V.
Number of connection : according to the intensity.
Nota : heating elements delivered without earth.

- Manufacturing according to the standard EN 60335-1
 - Wattage tolerance : +5%-10%
 - Leakage current < 0.75 mA/kW
- Special manufacturings :
 - Various shapes : manufacturing possible in circular shape (connection leads)
 - UL approved for the USA and CSA approved for the Canada. File number : E251509.
Define a special strip heater, p.8

CONNECTIONS FOR STRIP HEATERS

- Description of the various connections , with or without connection boxes :
 - Wires : Flexible wires, nickel core, fiberglass silk silicone sheath insulated (Max T° 340°C).
Only for unshield mica strip heaters : flexible leads, nickel copper core, insulated with silicone rubber (Max. T° 180°C).
 - Terminals : M4, M5 or M6 threads terminals, depending on the intensity , mounting in stamp, with 2 washers and 1 nut, for each terminal.
 - Stud bolt with 2 pins, 6 mm, gap 19mm, in nicked stainless steel. Connection box, other model of stud bolts in option. See p.6.
 - Nicked strip with a hole of diameter 4,5 or 6 mm for the connection, according to the intensity.
 - Braid (specific for termination with cap) : termination for leads, protected by a braid containing the 2 conductors, in galvanized steel.
- The heating elements are provided with earth wiring, by default, except for particular specifications. Delivery without earth wire on request.

CONNECTIONS WITHOUT CAPS :

- Legend
- Orientation of the connections

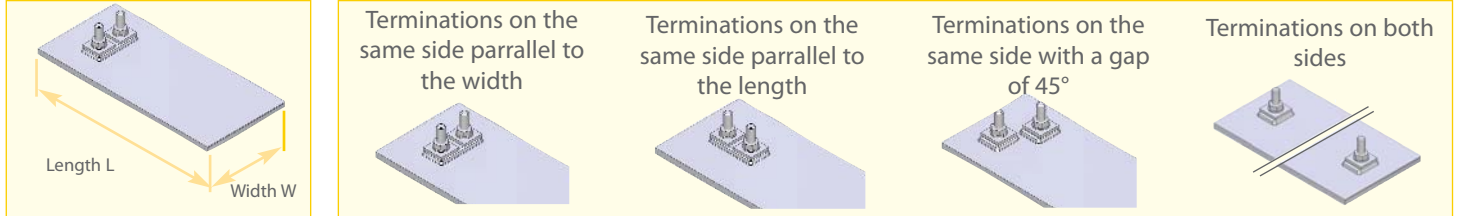

- The standard heating elements are in aluminized sheet or in stainless steel in option. The range of the dimensions are the same in these two cases, except for particular specification.
- The connection without cap, single phase, are centered on the width of the heating element. Gap of the connection : 19 mm.

Connection on the same side ⁽¹⁾

PINS - Intensity < 9.5 A

Mica strip heaters

- Parallel to the width
W : 45 to 424 mm / L : 80 to 1200 mm
- Parallel to the length
W : 25 to 50 mm / L : 100 to 1200 mm

Terminals - Intensity < 13.5 A

Mica strip heaters

- Parallel to the width
W : 45 to 424 mm / L : 80 to 1200 mm
- Parallel to the length
W : 25 to 50 mm / L : 80 to 1200 mm

Wires - Intensity < 20 A

Non metal sheath strip heaters

- Parallel to the width
Mini width : 30 mm / Max. dimensions : consult us.

Mica strip heaters

- Parallel to the width
W : 45 to 424 mm / L : 80 to 1200 mm
- Parallel to the length
W : 25 to 50 mm / L : 80 to 1200 mm

Wires in the thickness - Intensity < 13.5 A

Non metal sheath strip heaters (without strips)

- Parallel to the width
Mini width : 30 mm / Max. dimensions : consult us.

Mica strip heaters

- Parallel to the width
W : 50 to 424 mm / L : 80 to 1200 mm

Leads with strips - Intensity < 13.5 A

Mica strip heaters

- Parallel to the width
W : 65 to 424 mm / L : 100 to 1200 mm

Connection on both terminals

Wires on the leads - Intensity < 20 A

Non metal sheath strip heaters

- Width : 20 to 110 mm / Max. dimensions : consult us.

Mica strip heaters

- l : 25 to 111 mm / L : 80 to 1200 mm

Wires in the thickness - Intensity < 13.5 A

Non metal sheath strip heaters (without strips)

- Width : 20 to 110 mm / Max. dimensions : consult us.

Mica strip heaters

- W : 40 to 111 mm / L : 80 to 1200 mm

Leads with strips - Intensity < 13.5 A

Mica strip heaters

- W : 40 to 111 mm / L : 80 to 1200 mm

Terminals - Intensity < 13.5 A

Mica strip heaters

- W : 25 to 111 mm / L : 80 to 1200 mm

Connection with orientation to 45°

Pins - Intensity < 9.5 A

Mica strip heaters

- W : 40 to 424 mm / L : 80 to 1200 mm

Terminals - Intensity < 13.5 A

Mica strip heaters

- W : 40 to 424 mm / L : 80 to 1200 mm

Wires - Intensity < 20 A

Mica strip heaters

- W : 40 to 424 mm / L : 80 to 1200 mm

In case of a particular amount of space, consult us.

Possibility of adding some plugs, in option. See p.6

To define your quotation, refer p.8

Nota (1) : Nota : pictures represented with a disposition parallel to the width of the heating element. Possibility of orientation parallel to the length. Specify on request

Connection at right angle ⁽²⁾

Pins - Intensity < 9 A

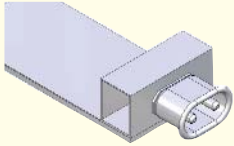

Mica strip heaters

- Parallel to the width
W : 80 to 1200 mm / l : 40 to 424 mm
- Parallel to the length
W : 80 to 1200 mm / l : 40 to 424 mm

Nota (2) : Picture represented with disposition parallel to the width of the heating elements.

Connection at right angle ⁽²⁾

Terminals - Intensity < 13.5 A

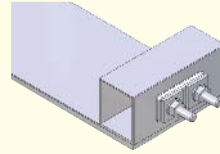

Mica strip heaters

- Parallel to the width
W : 80 to 1200 mm / l : 40 to 424 mm
- Parallel to the length
W : 80 to 1200 mm / l : 40 to 424 mm

CONNECTIONS WITH CAPS

- Description of the various connections : See p.4. Other models of connections, in option. See p 6. In case of a particular amount of space, consult us.
- Mica strip heater and cap : standard in aluminized sheet, stainless steel in option. Sealed mica strip heater and cap : every parts in brass or stainless steel. Disposition of the caps on the height : consult us.
- Model of caps below, for single phase connection. Possibility of three-phase, commutable or not, only for braid connection and terminal with threads.
- Refer to p 8 " how to define special strip heaters " to help you to define your quotation. Choose the connection type and fulfill the enclosed application form.

- Orientation of the connections

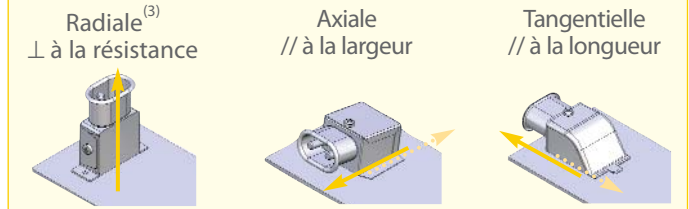

Légende : Disposition standard du capot, pour une orientation donnée. Disposition hors standard du capot

Orientation parallel to one side ⁽⁴⁾ - Axial - Tangential

Pins - Intensity < 16 A (single phase)

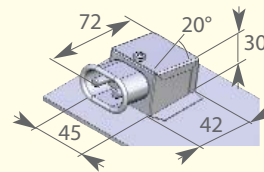

Mica strip heaters

- Tangential - Parallel to the length
W : 65 to 424 mm / L : 100 to 1200 mm
- Axial - Parallel to the width
W : 60 to 424 mm / L : 100 to 1200 mm

Terminals - Intensity < 13.5 A (single phase)

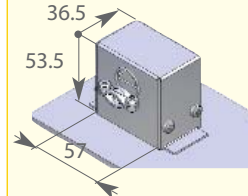

Mica strip heaters

- Tangential - Parallel to the length
W : 80 to 424 mm / L : 200 to 1200 mm
- Axial - Parallel to the width
W : 60 to 424 mm / L : 100 to 1200 mm

Braid + Cap type CMBPE, angle 30° - Intensity < 7.5 A (single)

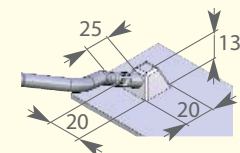

Mica strip heaters

- Tangential - Parallel to the length
W : 40 to 424 mm / L : 100 to 1200 mm
- Axial - Parallel to the width
W : 40 to 424 mm / L : 100 to 1200 mm

Sealed mica strip heaters

- Axial - Parallel to the width
W : 40 to 424 mm / L : 80 to 1200 mm

Other orientations : various angles, see p12.

Braid + small bulk cap - Intensity < 20 A (single)

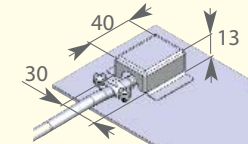

Mica strip heaters

- Tangential - Parallel to the length
W : 60 to 424 mm / L : 100 to 1200 mm

Axial - Parallel to the width

- W : 60 to 424 mm / L : 100 to 1200 mm

Also available in radial or tangential orientation.

Braid - Intensity < 20 A (single phase)

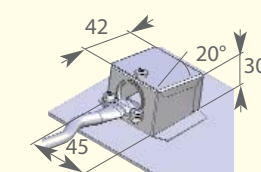

Mica strip heaters

- Tangential - Parallel to the length
W : 65 to 424 mm / L : 100 to 1200 mm
- Axial - Parallel to the width
W : 60 to 424 mm / L : 100 to 1200 mm

Perpendicular orientation to the heating element- radial ⁽³⁾

Pins - Intensity < 16 A (single phase)

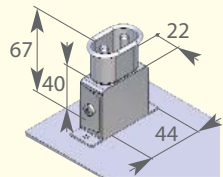

Mica strip heaters

- Radial - Parallel to the width
W : 65 to 424 mm / L : 100 to 1200 mm
- Radial - Parallel to the length
W : 35 to 424 mm / L : 100 to 1200 mm

Terminals - Intensity < 13.5 (single phase)

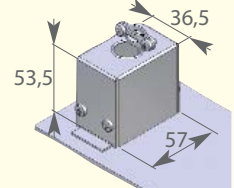

Mica strip heaters

- Radial - Parallel to the width
W : 100 to 424 mm / L : 200 to 1200 mm
- Radial - Parallel to the length
W : 80 to 424 mm / L : 100 to 1200 mm

Braid + Cap type CMBPE, angle 30° - Intensity < 7.5 A (single phase)

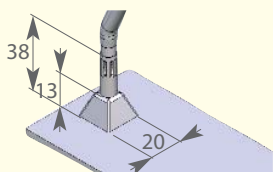

Mica strip heaters

- Radial - Parallel to the width
W : 40 to 424 mm / L : 100 to 1200 mm

Sealed mica strip heaters

- Radial - Parallel to the length
W : 40 to 424 mm / L : 100 to 1200 mm

Braid - Intensity < 20A (single phase)

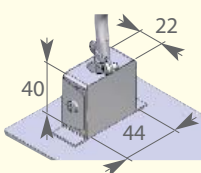

Mica strip heaters

- Radial - Parallel to the width
W : 65 to 424 mm / L : 100 to 1200 mm
- Radial - Parallel to the length
W : 35 to 424 mm / L : 100 to 1200 mm

Nota (3) : pictures represented with a radial cap orientation, parallel to the width. Possibility of radial orientation, parallel to the length. Specify on request

Nota (4) : Pictures represented with axial orientation cap, parallel to the width.

OPTIONS FOR MICA STRIP HEATERS

The options mentioned below are coming in complement to the options already listed in the previous definitions of products.

ACCESSORIES

Temperature sensor bridge



Mica strip heaters
Sealed mica strip heaters

Support inserted on the heater, then welded. Thread according to the diameter of the support :

∅	1/8	1/4	3/8	8	8	10	10	12	12	14	14	16
Thr.	gaz	gaz	gaz	100	125	100	150	100	175	100	150	100

Welded bracket



Mica strip heaters

Welded bracket which can be used as cable guides or clips for all kind of small equipment.

TEMPERATURE SENSORS

Thermocouple

Type J - 0 to 700°C
Type K - 0 to 1000°C

Mica strip heaters
Sealed mica strip heaters

2 possibilities:

- Insulated thermocouple: crimped under bossage, axial.
- Insulated or not insulated thermocouple integrated, brazed into a small cap type CMBPE (max. rated current 4.5 A)

MARKING

Special marking

By default:

Diameter	Height	Wattage
Voltage	Code	ACIM

Mica strip heaters
Sealed mica strip heaters

Modification of customized marking. Please, consult us.

SPECIAL MOUNTING

Compensation of plate



Mica strip heaters
Sealed mica strip heaters

Welded sheet which can compensate for the over-thickness of the folds of the sheet. It allows a homogeneous heating transfer with the part to be heated.

Shim plate

Sheet inserted in the heating element.

Mica strip heaters
Sealed mica strip heaters

System used when the thickness of the heating element is smaller than the thickness of its place.

Counter plate



Non metal sheath mica strip heaters
Mica strip heaters
Sealed mica strip heaters

Sheet with an important thickness which allows an efficiency slanting of the heating element on the part to be heated.

Other options are also available on the next page, among the examples of special strip heaters.

WIRING

Options for CMBPE type caps

Intensity : 7.5 A

Angle



Mica strip heaters
Sealed mica strip heaters

Possibility to combine options of angle and orientation cap.

Orientation

Axial

Radial

Tangential



CMBPE* type square cap



Mica strip heaters
Sealed mica strip heaters

Insulated brazed cap. Mention the angle and the orientation.

Extended tube on CMBE cap



Mica strip heaters
Sealed mica strip heaters

Option available for tubes longer than 25 mm. Please, mention the angle and the orientation.

UTFCEE plug



Mica strip heaters

2 pins plug 5x2 mm, gap 12.5mm + ground wire 6x2 mm, 240 Vac 16A. Dimensions : 88x33x63mm

Brazed stud bolts cap on CMBPE



Sealed mica strip heaters

2 pin plug, 6mm (diam), gap 19mm+ ground wire, in nickel steel. Dimensions : 88x51x28mm.

Mounting of special plug



Type CEE22

STAS.3.N (mâle)
STAK.3.N (femelle)

Sealed mica strip heaters

Plug CEE22 : 2 pins plug + ground, 400 Vac 16A.

Plug STAS : 3 pins plug + ground, 400 Vac 16A.

For any other type of plug, please consult us.

Leads with pearls

Protection of the leads for high temperature.

Length by multiple of 100 mm.

Mica strip heaters

Earth wiring or terminal

Please, specify it when you order, for heating elements which are not provided with earth wiring by default.

EXAMPLE OF SPECIAL STRIP HEATERS

To define this kind of strip heater, we request you to send your precise specifications. (see p.8 " how to define a mica strip heater). Pictures for information only.

Mica strip heater, provided with BAJ thermic insulation option and a anti-burning sheath

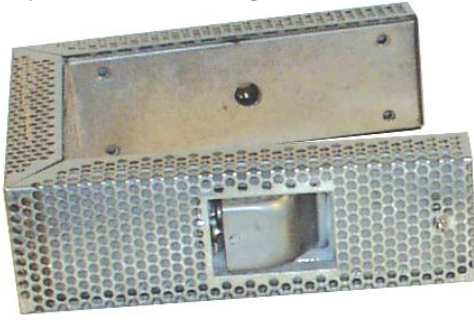

Mica strip heater, shaped in U, with holes in various forms.

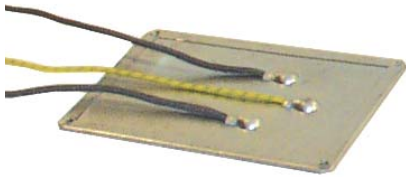
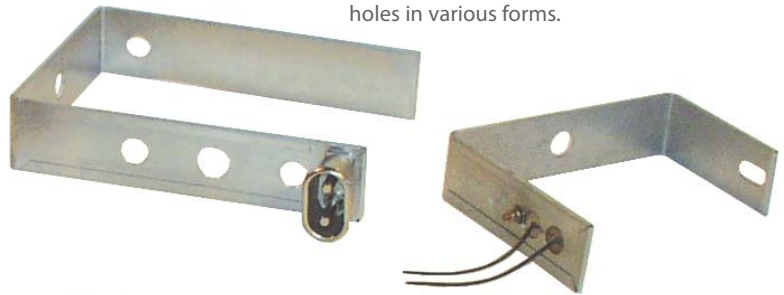

Mica strip heaters, provided with embossement connection and earth wire.



Circular mica strip heater, with a hole in the center.



Mica strip heater provided with a hole for fixation, connection under cap type CMBPE



Mica strip heater with a hole for fixation and provided with a counter plate in stainless steel which allows a good clamping.

ASSEMBLY RECOMMANDATIONS FOR STRIP HEATERS

In order to favour heating transfer between strip heaters and their support, it is necessary to respect some elementary recommandations

- Take care that the power of the heating element covers the heating needs. A heating element with too big dimensions will increase the risk of overheating and also the switching frequency of temperature controller, which could alter the life time of the strip heater.
- The mica strip heaters are manufactured to work according to the heating conduction principle : they have to be clamped and must not work in air. Only ceramic heaters can work in air, by wavelength.
- The surface in contact with the heating element must be polished, smooth , and must be cleaned before.
- The absence of metal plating makes the unshielded mica strip heater fragile. It is therefore necessary to protect them from mechanical point of vue, but also from external contamination by runoff such as water, oil and also from aggressive atmosphere.

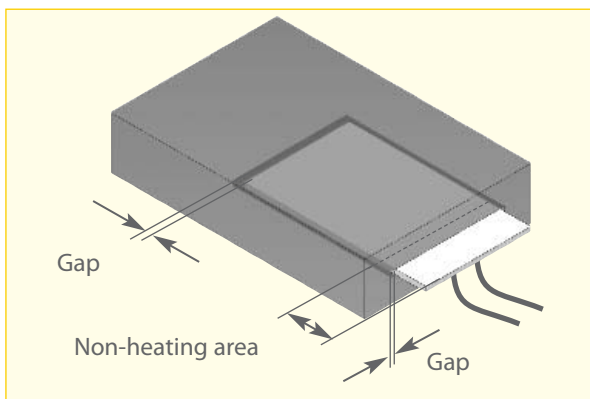

Recommanded disposition of the mica heaters :

- The heating elements have to be perfectly clamped on the piece to be heated which favour the heating transfer. It is necessary to let a little space in the length and the width to allow the expansion, in high temperature.
- The heating element and the connection have to be protected from potential introduction of material. So it is necessary to put the connection at the bottom.
- The part which is heating must absolutely be in the block to be heated. Only the non-heating part can be situated in the exterior of the block to be heated.

Our products specifications are subject to change without notice. We reserve the right to modify them according to the technical evolution

DEFINE A MICA STRIP HEATER

Also available on our web-site : www.acim-jouanin.fr

Company Tel : / Fax :
 Contact name : Department : Date :
 Brand of machine where the heater is installed on :

Type of mica strip heater : <input type="checkbox"/> Non metal sheath strip heater (p 3) <input type="checkbox"/> UL* <input type="checkbox"/> Mica strip heater (p 2) <input type="checkbox"/> UL* <input type="checkbox"/> Encapsuled mica strip heater (p 3) * UL approval	Dimensionnal of the mica strip heater : Length (mm) : Height (mm) : Wattage (W) : Voltage (V): Single / Three phase	Material of the heater : <i>except unshielded heaters</i> <input type="checkbox"/> Alumined steel <input type="checkbox"/> Stainless steel <input type="checkbox"/> Brass Number of pieces:
--	--	---

Connection : Surround the connection you wish. For the cable connection, please specify the kind of lead and the requested length

Connections on the same side					Connections under cap			
<input type="checkbox"/> // width* <input type="checkbox"/> // length	<input type="checkbox"/> // width* <input type="checkbox"/> // length	<input type="checkbox"/> // width* <input type="checkbox"/> // length						

* Sketch represented with a configuration of the connection parrallel to the length.

Connections on both sides				Connections with angle of 45°		

- Wire connection : Standard (fiberglass silk) High temperature wires Silicone cable Metallic braid Other :
- Length by multiple of 500 mm (mm) :
- Protection : Pearls Length (mm) :

Connections under cap				
Axial 				
Radial 				
Tangential 				

Sketch above, with a disposition of the connection stadard. For non-standard, please specify on the draw below.

- Braid connection : length by multiple of 500 mm (mm) :
- CMBPE cap : please specify the angle : 0° 45° Other :

Options and special manufacturings :

For the following information, please, specify the position and the dimensions on the sketch below.

Hole :
 Diameter (mm) : Quantity :

Cutout:
 Length x width (mm) : Quantity :

Temperature sensor bridge :
 Diameter + thread pitch:

Other options (all usefull information) :

.....

.....

This application form is only used to make a quotation. A sketch can be requested for the manufacturing

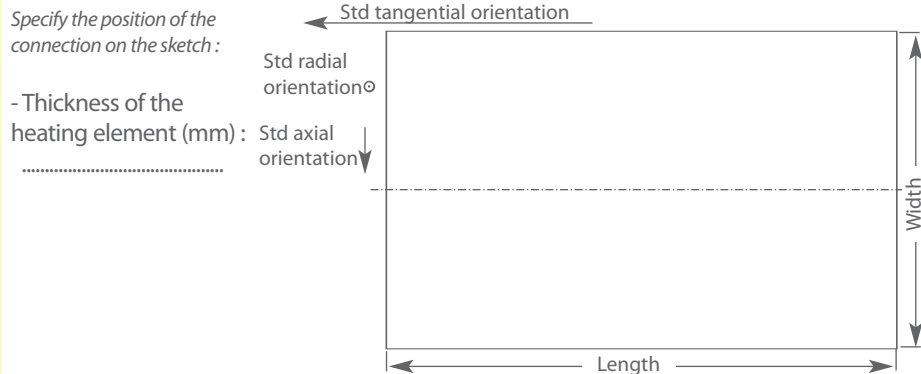

Working temperature :

Sensor :

Type of regulation :

Other information

.....

.....

.....

.....

Manufacturing of the heating elements which depends on the comptability of power, intensity, dimensional, connection, accessories and options.

ACIM JOUANIN - 650, Rue Vulcain - Z.I. n°1 Nétreville - BP 1725 - 27017 EVREUX Cedex - FRANCE
Tél : 33 (0)2.32.62.34.20 Fax : 33 (0)2.32.62.34.29 E-mail : export@acim-jouanin.fr Web : www.acim-jouanin.fr

Our products specifications are subject to change without notice. We reserve the right to modify them according to the technical evolution

Customer made heating elements .

- Max. watt density over the surface of the heater : 7 W/cm².
- Max. temperature on the strip heater : 900°C on the heating wire, according to the conditions using.
- Width : 83mm . Tolerance : -1/+2 mm.
- Total length : from 90 to 2000 mm. Tolerance : ± 2 mm.
 - Mini. length of the connection : 30 mm
 - Imperative heating length : 30, 60, 70, 90, 100, 120 mm. Beyond these dimensions, heating length by multiple of 10 mm.
 - Mini length of the terminal : 30mm.
- Thickness : 18 mm (set dimension). Tolérance : ± 1 mm.
- Standard metal frame in standard stainless steel sheet. (inconel in option, for high temperature).
- Electrical insulation with heat resistant ceramic elements.
- Connection :
 - Nickel core leads, insulated with silicone glass silk.
 - Length : 470mm, 100mm of which are under ceramic pearls.
 - Orientation :
 - same side, in the thickness
 - to 90° of the heating element
 - Number of leads : 2,3,4 or 6 according to the voltage.
 - Earth wiring by faston cable lug fixed on the metallic frame
- Voltage : 230 V or 400V. Other voltage on request.
 - Single phase : termination 2 and 4 leads ;
 - Three phases : termination 3 and 6 leads .
 - Termination 6 leads : three phase, switchable 230V/400V.
- Stainless steel fixation brackets : holes diam. 2.5 mm spaced out 88 mm. (Number of brackets depending on the length of the heater). Other fixation type upon request.
- Manufacturing according to the standard EN 60335-1
 - Wattage tolerance : +5%-10%
 - Leakage current < 0.75 mA/kW
- Special manufacturings :
 - Adding of a non-heating area between connection and heating area.
 - Define a ceramic strip heaters type radiant, refer to the application form p10. .



- Dimensional of a ceramic strip heater :

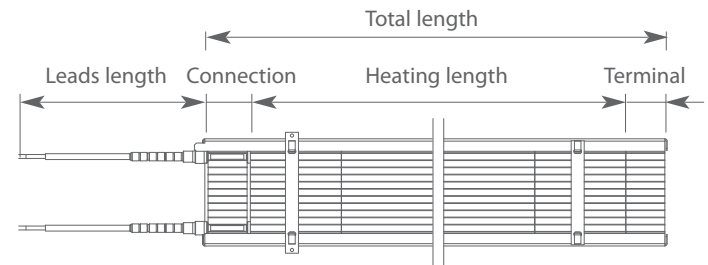

- Heater support

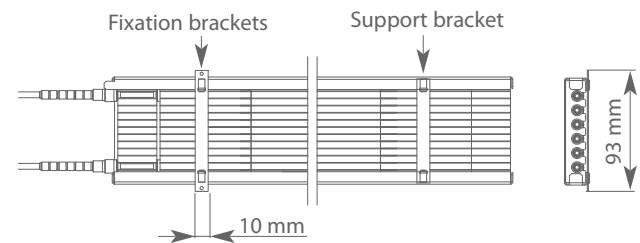

- Connection

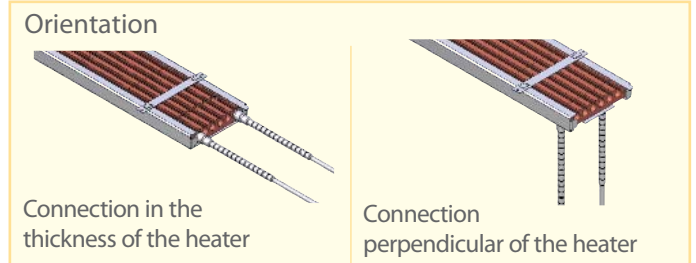

- Application

View of the inside of a tunnel heated by ceramic strip heaters type radiant



USING RECOMMANDATIONS FOR CERAMIC STRIP HEATERS

Information for ceramic heating elements type radiant and rigid.

- The heating elements can be set up in horizontal mounting (recommanded) or in vertical mounting (consult us). In vertical position, the leads tends to sink. Position to use with caution, according to the loading on the lead, the operating temperature and the heating power.
- The heating elements must not be clampéd because of the dilatation in high temperatures.
- The heating elements have to be protected from any form of external contamination because the absence of protection of the lead could imply short-circuit.
- Do not use the ceramic heating elements type radiant in corrosive atmospheres which could attack the heating wire.

RIGID CERAMIC STRIP HEATERS

Customer made heating elements .

- Max. watt density over the surface of the heater : 6 W/cm².
- Max. working temperature on the strip heater : 900°C.
These parameters depend on the using conditions.
- Heating width : from 15 to 250 mm (multiple of 15mm).
Full width : heating width + 5 mm of outside sheet.
- Total length : from 80 to 1500 mm (multiple of 15mm).
Mini length defined according to the type of connection
- Thickness : 11.5 mm (without connection).
- Covering sheet in aluminised sheet, by default.
Stainless steel or inconel according to the operating temperature.
- Electrical insulation by steatite elements.
- Connection : (see the sketch).
 - Nickel core leads insulated fiberglass silk silicone + earth wiring.
Orientation : - same side, in the thickness
- perpendicular the heating element
Please specify the length of the lead.
Possibility of protecting the leads with ceramic pearls.
 - Terminals with threads M4, M5, or M6 according to the intensity + earth wiring.
Orientation : perpendicular the heating element
- Voltage : 230 V single phase in standard. Max. voltage : 500V.
- Manufacturing according to the standard EN 60335-1
 - Wattage tolerance : +5%-10%
 - Leakage current < 0.75 mA/kW
- To define a rigid heating element, please fulfill the application form below.



- Connection orientation

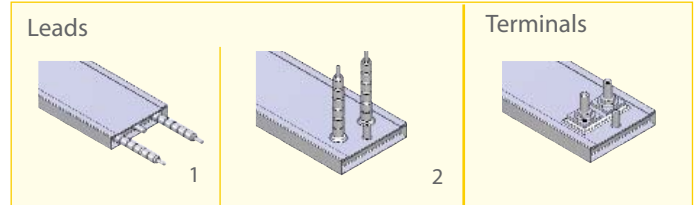

- 1 - Connection in the thickness of the heater
- 2 - Connection to 90° of the heater

- Voltage :
 - Single phase with possibility of switch 230 V/ 400V.
 - Three phases, 6 leads termination, non switchable.

Number of connections :

Heater width	Single phase	Three phase
< 90 mm	2 leads 2 terminals	/ /
> 90 mm	4 leads 4 terminals	6 leads 6 terminals

DEFINE A CERAMIC STRIP HEATER

Company Tel : / Fax :

Contact name : Department : Date :

Brand of machine where the heater is installed on :

Type de résistance : <input type="checkbox"/> Ceramic heater type radiant (p 9) <input type="checkbox"/> Rigid ceramic heater (p 10)	Dimensional of the heating element : Total length (mm) : (without connection) Total width (mm) : Wattage (W) : Voltage (V) : Single / Tree / Commutable	Material of the sheat : <input type="checkbox"/> Aluminised sheet (only for rigid ceramic heaters) <input type="checkbox"/> Stainless steel <input type="checkbox"/> Inconel															
Quantity of pieces :	Connection : Please, precise the type and the connection. For leads, precise length.																
Radiant ceramic strip heaters : - Heating length HL (mm) : - Possibly : Non heating length NHL1 (mm) : Non heating length NHL2 (mm) :	<table border="1"> <tr> <th colspan="2">Radiant ceramic heaters</th> <th colspan="3">Rigid ceramic heaters</th> </tr> <tr> <td><input type="checkbox"/></td> <td><input type="checkbox"/></td> <td><input type="checkbox"/></td> <td><input type="checkbox"/></td> <td><input type="checkbox"/></td> </tr> <tr> <td></td> <td></td> <td></td> <td></td> <td></td> </tr> </table>	Radiant ceramic heaters		Rigid ceramic heaters			<input type="checkbox"/>	<input type="checkbox"/>	<input type="checkbox"/>	<input type="checkbox"/>	<input type="checkbox"/>						<ul style="list-style-type: none"> • Leads connection : Length multiple by 500 mm (mm) : • Leads protection by ceramic pearls : Length (mm) :
Radiant ceramic heaters		Rigid ceramic heaters															
<input type="checkbox"/>	<input type="checkbox"/>	<input type="checkbox"/>	<input type="checkbox"/>	<input type="checkbox"/>													
Regulation : Regulation type : <input type="checkbox"/> ON/OFF <input type="checkbox"/> PID <input type="checkbox"/> Other : Temperature sensors : <input type="checkbox"/> Thermocouple J <input type="checkbox"/> Thermocouple K <input type="checkbox"/> PT 100 probe Model (bayonet ...) : Working temperature :																	

Our products specifications are subject to change without notice. We reserve the right to modify them according to the technical evolution

FLEXIBLE HEATING ELEMENTS

Silicone heating element are made of one heating element insulated between two sheets of silicone rubber reinforced by fiberglass. Flexible and little thickness, these heating elements are particularly fitted when the available space is limited.

These heating elements transfer their heat by conduction for application on supports of various shapes, in order to heat solids, liquids and gases.

Thanks to their internal manufacturing, the silicone elements allow to obtain a heating uniformly spread over the surface to be heated which avoid overheating points.

They are particularly adapted to applications which need a fast response of the heating system so a low thermic inertia of the heating element.

Strong, they can be used in some aggressives or humid areas.

Among the most standard applications, we will find the heating of the fragile products which impose a low density of power on the heating elements (W/cm^2).

The silicone heating element are notably used to maintain the temperature of drums, trays and other containers
The using is also possible in humid area, without risk of damages.

The silicone technology allows a manufacturing of the heating elements with various cuts in order to be perfectly adapted to your application.

In the case of specific application, the silicone insulating can be replaced by other material such as polyester or kapton.

- o **Silicone heaters** Traditional using
- o **Other material** Applications requiring low temperatures

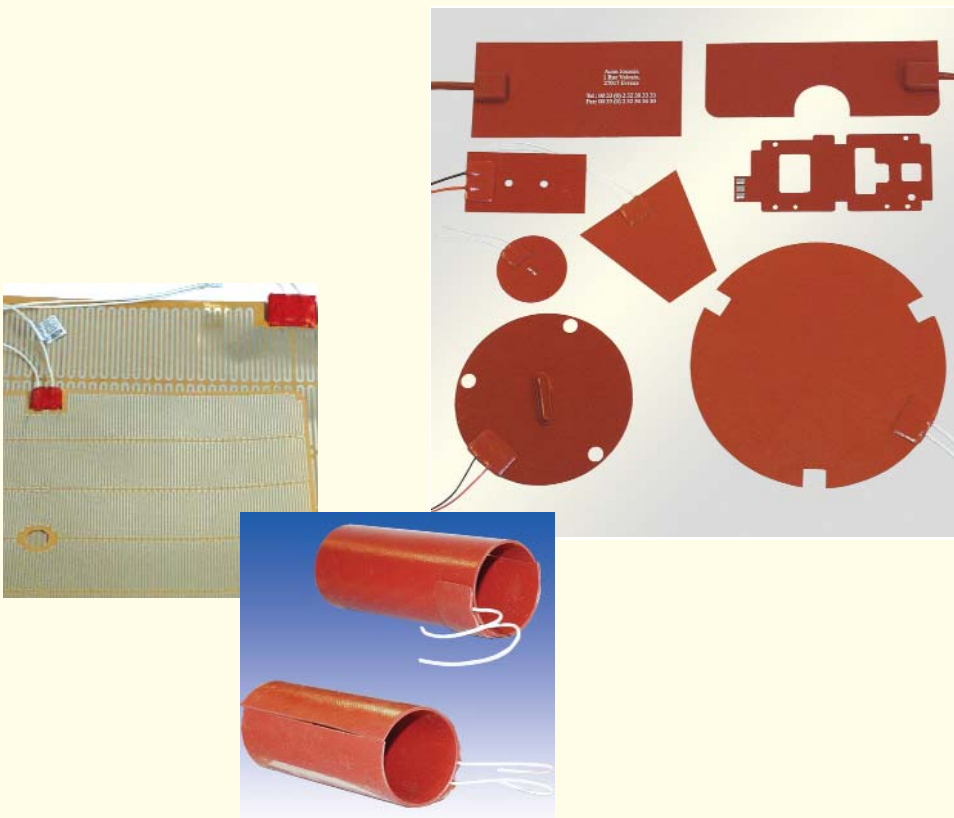

STANDARD HEATERS	
Silicone	p 12
NON STANDARD HEATERS	
Silicone	p 13
Kapton	p 14
Polyester	p 14
DEFINE A FLEXIBLE HEATER	p 14

STANDARD SILICONE FLEXIBLE ELEMENTS

- The silicone flexible heaters are used in many applications of heating and of maintaining temperature by conduction.
- Their low thermic inertia allows a fast response of the heating system.
- The internal design allows a heating uniformly spread on the surface of the heating element.
- Specific low loading which allows not to damage the fragile products.
- Strong, these heating elements can be used in some aggressive and humid areas. *(Subjected to further informations about application.)*

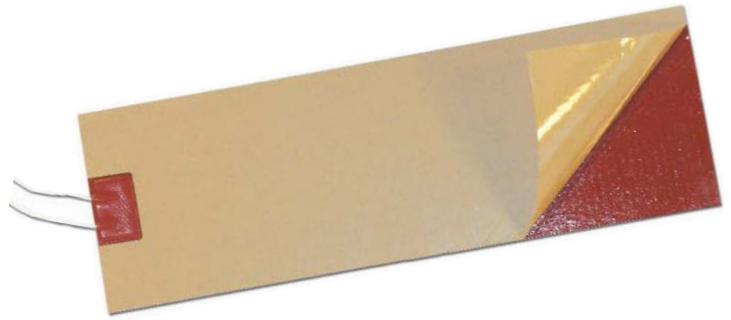

CHARACTERISTICS :

- Max. watt density over the surface of the heater : $0.7W/cm^2$.
- Max. working temperature on the strip heater : $200^{\circ}C$.
- Silicone elements are made of a resistive element insulated between two sheets of silicone rubber.
- Heater thickness : 1,5 mm (without connection).
- Voltage : 240V single phase in standard.
- Heating element provided with double electric insulation.
- Termination by 2 conductors insulated PTFE, under patch, centered on the width of the heating element. Length of the standard lead : 500mm.
- Fixation by high temperature adhesive, over the whole surface opposed to the connection.
- Marking by a sticker placed around the cable.
- Manufacturing according to the EEC, EMC, and CE standards for low voltage. Tolerance on power : $\pm 7,5\%$
- Mini bending radius 50mm.

References available within a week :

Dimensions (mm)		Wattage (Watts)	Codification
Width	Length		
100	150	50	SIL10X15X5
	150	100	SIL10X15X10
150	200	100	SIL15X20X10
	200	200	SIL15X20X20
200	300	200	SIL20X30X20
	300	400	SIL20X30X40
	400	267	SIL20X40X26
	400	533	SIL20X40X53

- Special manufacturing and options : see below. Heating elements which can be manufactured in other materials, for lower temperatures or more difficult conditions. Definition of those products p14.

CONNECTION :

Patch termination in the thickness + leads.
Dimensional : 25x35mm, thickness 3 or 4 mm.



OPTIONS and ACCESSORIES :

- The option supply belongs to the special manufacturing.
- Aluminium double sides scotch allows to position and reposition the heating element. (It applies to heating elements which are not provided with a system of fixation.)
- Holes and cuts on request. Please, specify it when you order.
- Thermocouple J,K or PT100 sensor put on the surface of the heating element (Picture : J thermocouple)
- Voltage : from 6V to 750 Vac.
- The heating element can be equipped with of a security systems such as : temperature controller, thermic fusible...for more safety.

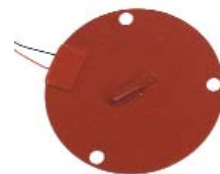
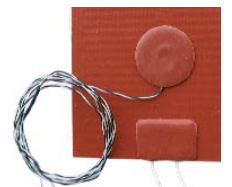

Heating element provided with an insulated thermic fusible



Heating element provided with an insulated temperature controller.



- The silicone heaters also exist in belt form, for big diameters. Consult our catalogue " drum heaters ".

- Customer made heating elements .
Special heaters range coming in complement of the standard products defined on the previous page.
- Max loading : 0.8 W/cm^2 . Possibility to increase the loading according to the application and the temperature control of the heating element.
- Maxi. operating temperature : 180°C .
- The silicone heating elements are made of a resistive element insulated between two sheets of silicone reinforced by the fiberglass.
- Thickness from 0.7mm to 1.5 mm according to the application and the technical characteristics (power, dimensions,...)
- Termination : - in the thickness, under patch + leads (see p. 12)
- under bossage+ silicone insulated cable (opposite)
- Voltage : 240Vac single phase, by default. Other voltage on request.
- Heating elements insulated by a double electric insulation.
- Manufacturing according to EEC, EMC, and CE on the low voltage.
Tolerance on power : $\pm 7.5\%$
- Special manufacturing : UL approved for the USA and CSA for the Canada.

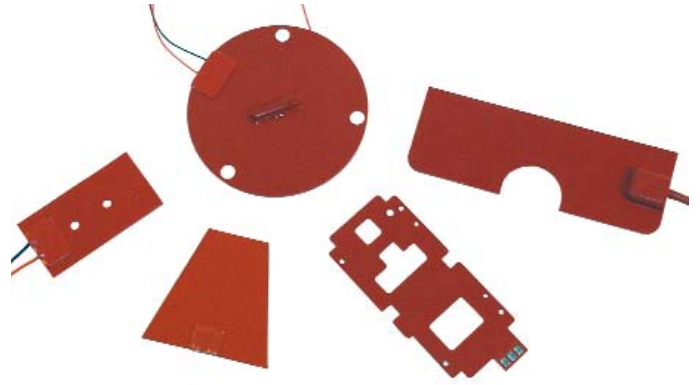

CONNECTION :

Termination for cable with 2 conductors, under bossages. Termination situated on the extremity of the heating element. Dimensional : 25 x 25 mm, thickness 8 mm.



POSSIBLE SHAPES : Below, the most requested shapes. Other shapes are possible with a special manufacturing. The given dimensions depend on the compatibility with the power of the heating element.

• Rectangular shape :

Length. : mini : 20 mm / maxi. : 3000 mm.
Width. : mini : 10 mm / maxi. : 940 mm.

Termination centered on the width

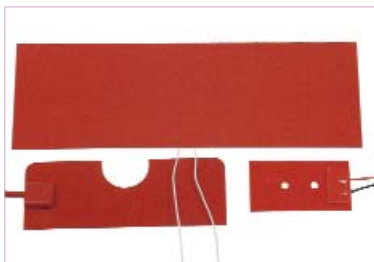

• Circular shape :

Diameter : mini : 20 mm / maxi : 900 mm.

Termination situated on the side



• Cylindrical* shape :

Inside diam. : mini : 15 mm / maxi : 600 mm.
Length. : mini. : 50 mm / maxi. : 1000 mm.

Termination on the opposite side of the opening

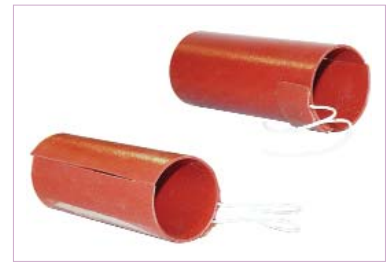

* From diameter 15mm to 100mm the silicone flexible heating elements are delivered already shaped. Beyond these diameter, they delivered flat and are shaped directly by the customer.

TYPES OF TIGHTENING FOR THE CYLINDRICAL HEATERS : available in option.

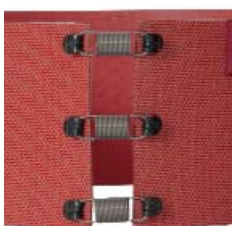

Hook + spring



Reinforced eyelet + lace



Velcro
(in the picture, mounted on an insulating element - not included)



Strap

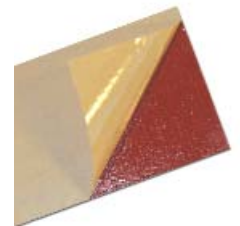

Self-adhesive surface

SPECIAL FLEXIBLE ELEMENTS

- Heating elements customer made.
- The heating element is engraved, using a technology similar to printed circuits. Then, it is placed between two sheets of electric insulation of the same material.
- There are 2 kinds of electric insulation :
 - Kapton : made for applications which need a low degassing. It resist to corrosive products and can be used for the vaccum work.
 - Max. temperature : 200°C
 - Max. loading : 3 W/cm²
 - Thickness : 0.2 mm (without connection)
 - Polyester : model of heater considered as an economic solution to the other kind of electric insulation.
 - Max. temperature: 120°C
 - Max. loading : 0.3 W/cm²
 - Thickness : 0.5 mm (without connection)
- The heating elements are manufactured according to precise specifications and after a feasibility study.

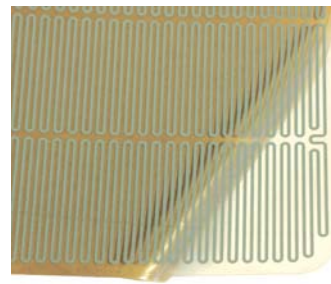
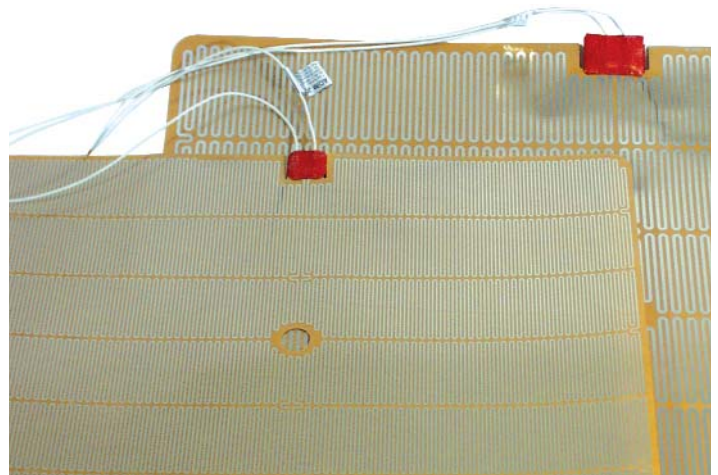

Detail of the part heating
(Fixation by adhesive face)

DEFINE A SPECIAL FLEXIBLE ELEMENT

Company		Tel : / Fax :	
Contact name :		Department : Date :	
Brand of machine where the heater is installed on :			
<ul style="list-style-type: none"> • Information about the using area : • Waterproof : 		<ul style="list-style-type: none"> • Using temperature : • Type of temperature control : • Quantity 	
Material : <input type="checkbox"/> Silicone <input type="checkbox"/> Kapton		Shape : <input type="checkbox"/> circle <input type="checkbox"/> rectangular <input type="checkbox"/> square	
Diameter / Length (mm) : Height (mm) : Wattage (W) : Voltage (V): single-phase			
Termination * : In case of imperative dimensional, please indicate it. <input type="checkbox"/> Patch termination in the thickness <input type="checkbox"/> Termination under bossages Length of the leads or cable by multiple of 500 mm (mm) :			
Fixation : <input type="checkbox"/> Without <input type="checkbox"/> Adhesive surface <input type="checkbox"/> Hook+spring <input type="checkbox"/> Eyelet+lance <input type="checkbox"/> Velcro Without precision about the fixation, the delivered heater will be naked.			
Options* : n°			
<input type="checkbox"/> Fixation : aluminised scotch <input type="checkbox"/> Regulation system : <input type="checkbox"/> temperature controller/ activating point (°C) : <input type="checkbox"/> Control sensor : J thermocouple K thermocouple PT100 Leads sensor length (mm) : <input type="checkbox"/> Cut : Manufacturing according to the feasibility study. Please supply the drawing - Hole : diameter (mm) : - Cut : length x width (mm) : - Quantity : - Angular value from the opening : 90° 180° Other : - Position on the height : centered decentered (specify the position on the sketch)			
Particular information regarding the options :			
* In case of imperative dimensional , indicate it.			

Our products specifications are subject to change without notice. We reserve the right to modify them according to the technical evolution



Temperature control



Band heaters



Fan heaters



Flexible heaters



Immersion heaters



Tubular elements



Cartridge heaters



Formable coil heaters



Infrared emitters



Flat (plate) heaters



Ovens



Barrel heating



Cast in heaters



Cables, sheath and accessories

But also other families : Tracing, heaters on cylinder



ACIM JOUANIN
Z.I. N°1 Nétreville
650, Rue Vulcain - B.P. 1725
27017 EVREUX Cedex
FRANCE



Tel : 00 33 2 32 62 34 20
Fax : 00 33 2 32 62 34 29



E-mail : export@acim-jouanin.fr
Web site : www.acim-jouanin.fr

Distributor :

